

SEWER MANHOLE SEALING

(As provided by Avanti International)

- 1 Intent: The intent of this section is the elimination of infiltration/inflow into manholes that are otherwise structurally sound, using various products and methods either singularly or in combination.

- 2 General: Sewer manhole sealing includes the following ...
 - (2.1) The sealing of the manhole base, walls, corbel/cone and chimney of brick, block or precast manholes.
 - (2.2) The sealing of precast manhole barrel joints, when general structure sealing is not required.
 - (2.3) The sealing of the manhole frame joint area and the chimney above the cone.
 - (2.4) The sealing of manhole covers by either replacement, conversion or by installing a manhole insert.
 - (2.5) The inspection and testing of the various types of work to insure compliance.

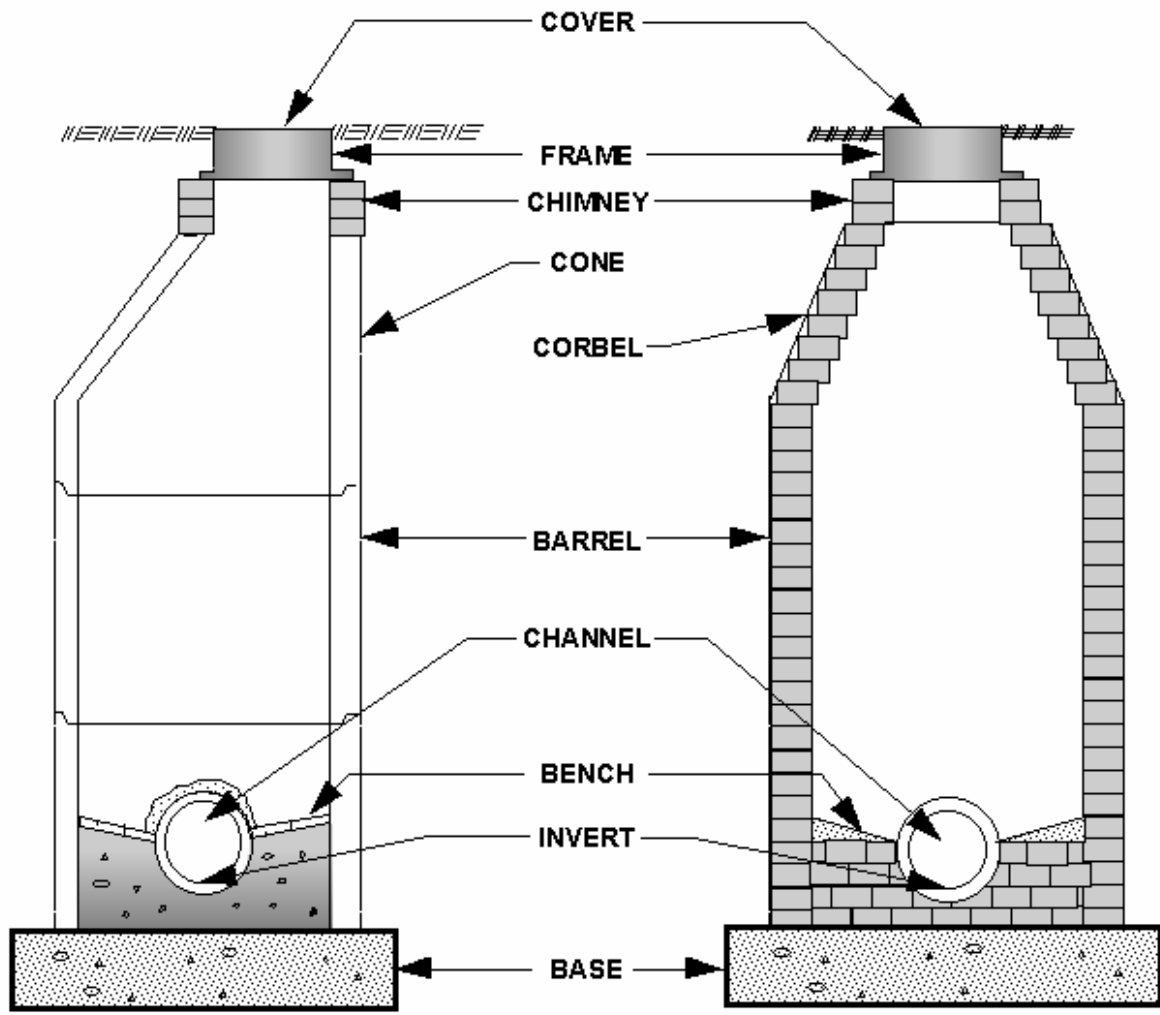

TYPICAL PRE-CAST MANHOLE

TYPICAL BRICK MANHOLE

BASIC MANHOLE COMPONENTS

3 Manhole Structure Sealing: Manhole structure sealing includes the sealing of the manhole base, walls, corbel/cone and chimney. This type of sealing shall be done during high groundwater conditions, unless the points of leakage have been previously identified.

- (3.1) Chemical Grout Sealing: Shall be in accordance with ASTM F2414-04 Standard Practice for Sealing Sewer MANHOLES Using Chemical Grouting.
- A Chemical Sealing (Grouting) Materials: Shall meet the requirements specified in the chemical sealing materials section with special attention focused on the safety training requirements as well providing product liability insurance for all materials used.
 - B Equipment: The basic equipment shall consist of chemical pumps, chemical containers, injection packers, hoses, valves, and all necessary equipment and tools required to seal manholes. The chemical injection pumps shall be equipped with pressure meters that will provide for monitoring pressure during the injection of the chemical sealants. When necessary, liquid bypass lines equipped with pressure-regulating bypass valves will be incorporated into the pumping system.
 - C Sealing Procedures (Precast Manholes): At each point of leakage within the manhole structure a hole shall be carefully drilled from within the manhole and shall extend through the entire manhole wall. In cases where there are multiple leaks around the circumference of the manhole, fewer holes may be drilled, providing all leakage is stopped from these holes. Grout ports or sealant injection devices shall be placed in these previously drilled holes in such a way as to provide a watertight seal between the holes and the injection device. A hose, or hoses, shall be attached to the injection device from an injection pump. Chemical sealing materials as specified (see CHEMICAL SEALING MATERIALS) shall then be pumped through the hose until material refusal is recorded on the pressure gage mounted on the pumping unit or a predetermined quantity of sealant has been injected. Care shall be taken during the pumping operation to insure that excessive pressures do not develop and cause damage to the manhole structure. Upon completion of the injection, the ports shall be removed and the remaining holes filled with mortar and troweled flush with the surface of the manhole walls or other surfaces. The mortar used shall be a nonshrink patching mortar (see SEWER MANHOLE REHABILITATION).
 - D Sealing Procedures (Brick and Block Manholes): When chemical grouting is used to seal random or isolated leaks or leaking sections of a brick or block manhole, it shall be done in accordance with 3.1 B, above.
 - E Grout Curtain Sealing Procedures (Brick and Block Manholes): When a chemical grout curtain is required around a brick or block manhole, the procedure may involve the use of chemical grout in combination with a two-coat cementitious coating.
 - a Surface Preparation: The manhole surface shall be cleaned, patched, and the infiltration stopped as required (see SEWER MANHOLE REHABILITATION).
 - b Set Grout Ports or Injectors: Holes shall be drilled and grout ports or chemical sealant injection devices installed to insure proper grouting of the soil outside of the manhole. Some additional ports may be placed after the application of the waterproof coating.
 - c Coating: Two coats of a cementitious waterproof coating shall be applied as required (see SEWER MANHOLE REHABILITATION) before any chemical grout is pumped. These two coats will provide a dam to optimize the grout sealing application and shall extend from the manhole base to the bottom of the frame seal.

- d Chemical Sealing: Chemical grout shall be injected into the soil surrounding the manhole as needed for complete sealing, using the same equipment and procedures as required earlier in this section. Grouts injected into near-surface and chimney-corbels areas may require the addition of shrink control agents, gel reinforcing agents and accelerators.

<u>Sealing Material</u>	<u>Suggested Additive</u>
AV-100 Acrylamide Gel	AV-257 Icoset Latex
AV-118 Acrylic Gel	AV-257 Icoset Latex
AV-350 Urethane Gel	AV-257 Icoset Latex
AV-202 Polyurethane Resin (foam)	

- (3.2) Cementitious Sealing: Manhole structure sealing, as well as the sealing of random and isolated leaks, can also be accomplished by using the cementitious method (see SEWER MANHOLE REHABILITATION).

4 Precast Manhole Joint Sealing: Precast manhole joint sealing includes the sealing of barrel joints using one of the following methods and procedures when general structure sealing is not required.

- (4.1) Chemical Grout Sealing: Use the same procedures and materials as required in 3.1 B.
- (4.2) Cementitious Sealing: Use the same materials as required in SEWER MANHOLE REHABILITATION.
- (4.3) Expanded Gasket: Use the elastomeric polyurethane resin-soaked oakum method, using dry twisted jute oakum or resin rod with polyurethane resin (water activated).
- (4.4) Manufactured Seal: Install a manufactured manhole joint seal that generally conforms to the requirements of 5.1 with a stainless steel restraining hoop. Detailed installation procedures shall be in accordance with the manufacturer's instructions.

5 Manhole Frame Sealing: Manhole frame sealing includes the sealing of the frame joint area and the chimney above the cone of the manhole with either a manufactured or applied internal or external flexible seal. The seal shall be designed to prevent leakage of water into the manhole through these areas throughout a 20-year design life. The seal shall remain flexible, allowing repeated vertical movements of the frame due to frost lift, ground movement, or other causes of up to 2 inches and/or repeated horizontal movement of the frame due to thermal movement of pavement or other causes of up to 1/2 inch.

- (5.1) Manufactured Frame Seal: If the flexible portion of the seal is made of a rubber type product, it shall have a minimum thickness of 3/16 inch, a minimum unexpanded width of 8 inches, and be fabricated from a high-grade rubber compound conforming to the applicable requirements of ASTM C-923. The internal seal shall have a double pleated and the external seal a corrugated, expandable center section. Any extension used in conjunction with the sleeve to increase coverage shall be made of the same material and have the same minimum thickness as the sleeve and be designed to be mechanically attached to the sleeve. The bands used for compressing the sleeve and extension against the manhole shall be fabricated from minimum 16-gauge sheet, if channeled, or 5/16-inch diameter, if round, stainless steel conforming to ASTM A-240, Type 304, for sheet and ASTM A-479, Type 304, for rods. Any screws, bolts or nuts used on these bands shall be stainless steel conforming to ASTM F-593 and 594, Type 304. The internal seal or its appurtenances shall not extend far enough into the manhole opening to prevent or unduly restrict manhole entry. If the seal is constructed of another flexible material, it shall have

both tensile and tear strength equal to or greater than that of the rubber when tested in accordance with the applicable ASTM procedures.

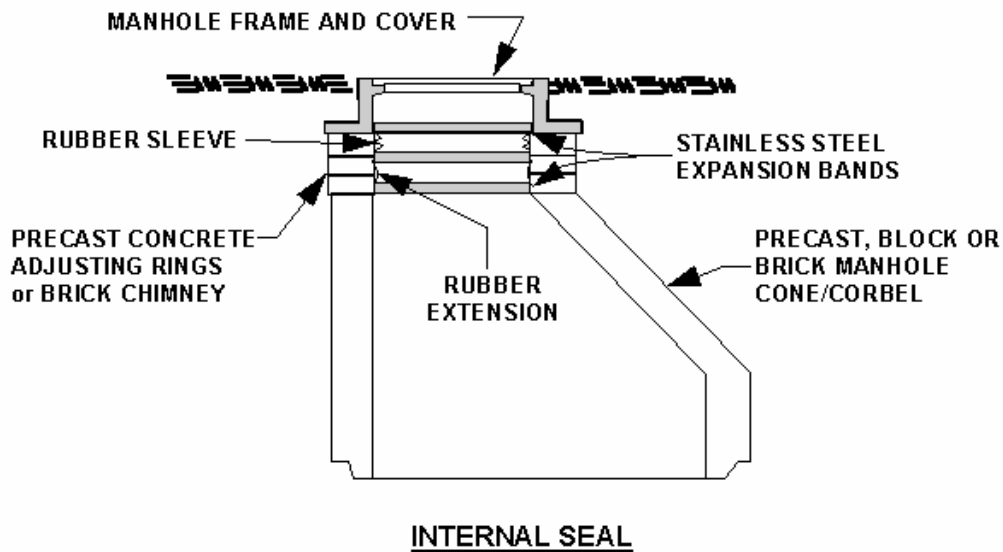

Installation: The contact surfaces for the sleeve and extensions shall be clean, reasonably smooth and circular, and free of excessive voids. If the masonry surface is rough or irregular and will not provide an effective seal, it shall be smoothed with mortar. A bead of butyl rubber caulk may be applied to the bottom sealing surface of the seal or extension to fill minor irregularities in the masonry surface. After the rubber sleeve has been placed in the proper position, the bands are positioned and individually tightened or expanded as required to provide a watertight seal.

When an extension is used, its top shall be positioned in the bottom band recess prior to installing the bottom band. The bands are then positioned in the extension and tightened or expanded as required to provide a watertight seal. Installation procedures shall be in accordance with the manufacturer's instructions.

- (5.2) Applied Frame Seal: An applied seal is one that is achieved by applying a product, approved by the Engineer, either between the precast adjusting rings of the chimney and under the frame or to either the inside or outside surface of the chimney and frame to provide a seal that meets the performance criteria contained in this section. If the applied sealing product is a butyl or mastic type compound, all of the surfaces that are to be sealed shall be clean, dry, and dust free.

If the applied seal utilizes the elastomeric polyurethane resin-soaked oakum method, each joint shall consist of two concentric rings of 2-inch oakum. The outer ring shall be saturated with the urethane base foam chemical sealing material. The inner ring, saturated with water, shall be placed to prevent urethane foam from entering the manhole. The oakum saturated with urethane shall be sprayed with water. When foaming begins, the frame shall be set in place.

If the applied sealing product is a type of material that is applied to either the inside or outside surfaces of the frame and chimney and/or corbel/cone, the surface against which it is applied shall be clean, and free of rust, dust, oil, loose material and other contaminants. The product shall be applied by trowel, roller, or by spraying to achieve a thickness of not less than 100 mils. The sealing material shall extend far enough onto the frame to insure bonding and cover enough of the chimney to insure sealing. If the sealing material is applied to the outside of the manhole, it shall be allowed to cure a minimum of 24 hours before backfilling when the ambient temperature is above 70°F and 48 hours when the ambient temperature is below 70°F and falling. Immediately

before backfilling, two layers of 4 mil plastic sheet shall be loosely wrapped over the sealed area to prevent direct contact between the sealer and the backfill material.

Application procedures shall be in accordance with the manufacturer's instructions.

- (5.3) External Sealing System: The manufactured frame seal: It shall be multi-section continuous bands, with a neoprene rubber top section and all lower sections made of EPDM (Ethylene Propylene Di Monomer) rubber with a minimum thickness of 60 mils that meets or exceeds the ASTM specification C-923. Each unit shall consist of a top and a bottom section and shall have mastic on the top and bottom of the top section and on the bottom of the bottom section. The mastic shall be non-hardening butyl rubber sealant that meets or exceeds ASTM Specification 0990-94 and shall seal to the cone/top of the manhole/catch basin and over the lip of the casting.

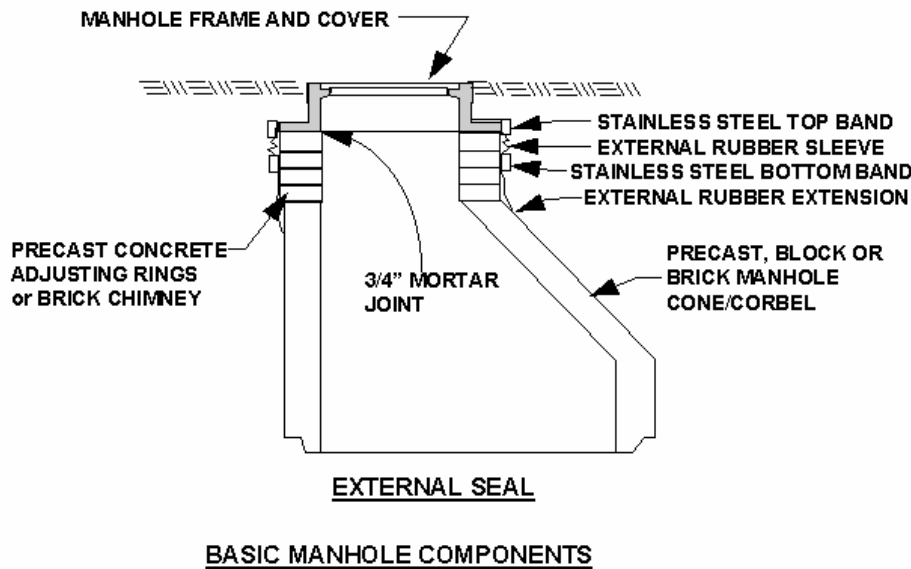

INSTALLATION:

Suggested tools for application: Tape measure, Hand Held broom, Heavy Duty Scissors, Abrasive Stone (or other object to remove sharp edges).

Product. The frame seal External Sealing System consists of two sections, the bottom section "A" and top section "B". Additional extension sections "C" are available if necessary.

Excavate dirt from around the structure to depth of 4" below the top of the cone/top slab. Using an abrasive stone or other object, remove any sharp, protruding edges from the outside surface of manhole or catch basin adjustment ring area.

Also remove any dirt clumps or mortar chunks from the casting flange where the mastic is intended to adhere. Brush Frame seal Adhesive Primer onto the casting and structure surfaces where the mastic is intended to adhere. After the Adhesive Primer has dried (approximately 10 minutes) begin placing the external unit onto the structure. Unfold and stretch bottom section "A" around the structure. Lower section "A" into position so that its bottom edge is a minimum of 2" below the top of the cone/top slab. Flip mastic strip up - facing out. Using a heavy duty scissors or utility knife, cut off the portion of the top band that extends above the casting flange. Pull top section "B" over the structure (wider mastic towards the top) until its top edge is 1 1/2" above the bottom edge of the casting. The bottom edge of top section "B" should overlap bottom section "A" by a minimum of 2" or an extension section "C" will be required. Flip top and bottom mastic strips

up - facing out. Remove the release tape from the mastic strips, flip mastic strips down and hand press into position. Installation complete.

6 Manhole Cover Sealing: Manhole cover sealing includes either the replacement of or sealing of existing manhole covers. All of the methods described require the thorough cleaning of the frame rim surface by wire brushing. Detailed installation procedures shall be in accordance with the manufacturer's instructions.

(6.1) Cover Replacement: Replace the existing cover with a new approved solid, gasketed cover.

(6.2) Cover Conversion: Reuse the existing cover by making it watertight. This is accomplished by installing a gasket between the cover and the cover-bearing surface of the frame and plugging the vent and pick holes. One of the plugs shall be removable to facilitate removal of the cover.

Manhole cover gaskets and plugs shall be molded from a high-quality rubber compound such as Nitrile, EPDM or a blend thereof. The rubber product shall have a minimum tensile strength of 2,000 psi with a hardness (durometer) of 60 ± 5 . The cover gasket shall be provided with an outside rib and have a minimum thickness of 3/32 inch.

(6.3) Installation of Manhole Insert: Use the existing cover in conjunction with a watertight insert that is installed under the cover and prevents entry of water into the manhole. The manhole insert shall be designed to prevent inflow through and around manhole covers and manufactured to fit the manhole frame rim upon which the manhole cover rests.

A The manhole insert shall be manufactured from a corrosion-resistant material able to withstand the environment of a sanitary sewer system, road salts, oils and fuel that it may come in contact with. The material shall be freeze-thaw resistant and withstand a temperature range of -50°F to 245°F . The manhole insert shall have a minimum thickness of 1/8 inch.

B The insert shall have an approved system of relieving gas and vacuum pressure and shall be complete with a closed-cell neoprene or polyethylene gasket with adhesive backing installed on the underside of the insert rim by the manufacturer. The insert shall have a corrosion-resistant strap installed within the bowl for ease of installation and removal.

C The manhole insert shall be fully seated upon the manhole frame rim and the cover replaced to complete the installation.

7 Final Acceptance: After the specified sealing work has been completed, the manholes shall be visually inspected and tested by the Contractor (as required) in the presence of the Engineer and found to be acceptable.

(7.1) Structure Sealing Test: Manhole structure sealing shall be visually inspected for watertightness against leakage of water into the manhole. All visible leaks and defects observed during inspection shall be repaired to the Engineer's satisfaction.

If the groundwater level is not, in the opinion of the Engineer, high enough to give a realistic visual inspection, the Contractor may, at his option, test a random sampling of the manholes using one of the following methods.

A Exfiltration Testing: Incoming and outgoing sewer service lines shall be plugged, the plugs restrained and the manhole filled with water to the top of the manhole frame. A soaking period of up to 1 hour will be allowed if bypassing of the sewage is not required or has

been provided for. At the end of this optional soaking period, the manhole shall be refilled with water and the test begun.

If the water loss exceeds that shown in the following table, the manhole will have failed the test.

<u>Depth of Manhole</u>	<u>Maximum Allowable Loss</u>
Under 8 feet deep	1 inch in 5 minutes
Over 8 feet deep	1/8-inch per foot of depth in 5 minutes

B Vacuum Testing: All incoming and outgoing sewer and service lines shall be plugged, the plugs restrained and the vacuum tester head placed on the manhole frame and sealed. A vacuum of 10 inches Hg shall then be drawn on the manhole and the time measured for the vacuum to drop to 9 inches Hg. This time shall not be less than 40, 50, or 60 seconds for manhole diameters of 48, 60, and 72 inches respectively. For manholes deeper than 20 feet, the test times shall be increased by 2 seconds per foot of additional manhole depth.

* * *

If exfiltration of vacuum testing is used, a minimum of 10 percent of the sealed manholes as chosen by the Engineer shall be tested. Manholes that fail shall be reworked and retested by the Contractor at no additional compensation. If more than 5 percent of the manholes tested fail the initial test, an additional 10 percent of the sealed manholes shall be tested. This process will continue until the testing is satisfactory, or until all manholes have been tested.

Limitation and Considerations: It must be recognized that exfiltration and vacuum testing may be impractical or cost-prohibitive for all manholes; therefore the use of either method is subject to the following limitations and considerations.

Complete Sealing: These methods shall be used only when the entire manhole has been sealed or rehabilitated. The lack of sealing or rehabilitation of some portions of the manhole may prevent passage of either of these tests. Spot repairs and partial sealing or rehabilitation shall therefore be subject to infiltration and visual testing only.

Coating or Lining: These methods shall not be used on manholes that have had a cementitious coating applied or lining installed until the coating or lining has been cured according to the manufacturer's recommendations.

Inlet and Outlet Sewers: Manholes built over large diameter sewers may be impractical and uneconomical to test using either of these methods due to bypassing requirements, availability of plugs, and high forces that are generated on the plugs. Consideration must be given to these factors when determining the method of acceptance testing to be used.

Structural Condition: The structural condition of some manholes may be such that testing with these methods is impractical or destructive. Manholes that have not been structurally lined shall therefore be deemed as structurally sound by the Engineer and Contractor prior to testing using these methods.

- (7.2) Precast Manhole Sealing Test: Acceptance testing shall be done using the method described in paragraph 7.1 above.
- (7.3) Frame Sealing Test: Manufactured frame seals shall be visually inspected to insure that the sleeve is properly positioned, tight against the manhole surfaces, that no voids or leakage points exist under the sleeve and that the bands and locking nuts are tight. This inspection shall be made prior to backfilling when an external seal is used.

Applied seals shall be visually inspected to insure that they have been applied according to the manufacturer's instructions.

Manhole frame sealing shall be randomly tested for leakage using a method approved by the Engineer. A minimum of 10 percent of the sealed manholes shall be tested. Manholes that fail shall be reworked and retested by the Contractor at no additional compensation. If more than 5 percent of the manholes tested fail the initial test, an additional 10 percent of the sealed manholes shall be tested. This process will continue until the testing is satisfactory, or until all manholes have been tested.

- (7.4) Cover Sealing Test: The sealed manhole covers shall be visually inspected to insure that the bearing surface was properly cleaned and that products were properly sized and installed according to the manufacturer's instructions.

Any manholes that are leaking, are visually unacceptable, or fail the test shall be reworked and retested. The Contractor shall be reimbursed for the cost of this additional work if an inspection by the Contractor and the Engineer shows that the work performed by the Contractor was not the reason for the failure of the manhole to pass the leakage test. The Engineer reserves the right to inspect the sealed manholes during the warranty period. Any leakage or defects in the work found by this inspection shall be corrected by the Contractor within an agreed-upon time at no additional cost to the Owner.